

TEST TERMINAL

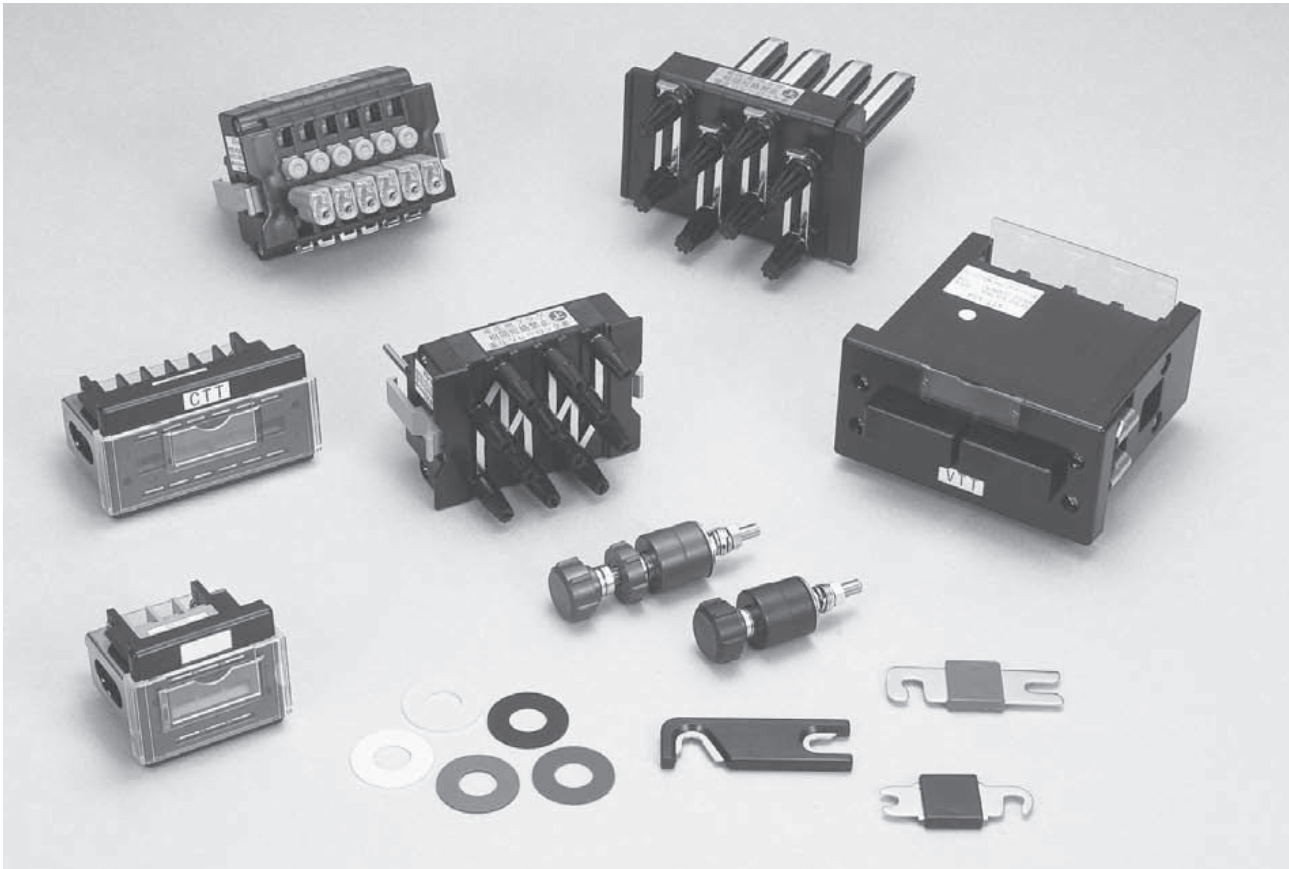

FEATURES

■ Simplified calibration and testing procedures

Our test terminals allow you to perform calibration and testing procedures with instrument and relays connected in place, resulting in great labor saving.

■ Broad range of applications

Our test terminals are available in a broad range of types including the stud type and insertion type to meet your current capacity requirements ranging from 5 to 30A and your applications.

■ Safety structure

Our test terminals for CT circuits are designed to prevent the circuit open. Both of the insertion type test terminals

for PT and CT circuits assure safety with their structure that prevents wrong insertion.

■ High insulation and anti-inflammability

For the housing material, high-performance engineering plastics is used to provide high insulation, anti-inflammability, and impact resistance.

■ Special spec for tropical region

To ensure high durability in harsh use under tropical regions, special protective treatment is applied to some products, which are available in the same ratings, performance, and dimensions as those of the standard products.

SPECIFICATIONS (RATINGS, PERFORMANCE)

Specification	Type	B-TYPE	K-TYPE	A-TYPE
Rated insulation voltage (Ui)		250V	500V	250V
Rated current-carrying capacity (Ith)		10A *	10A	5A
Max. wire size		8mm ²	5.5mm ²	2mm ²
Withstand voltage		1 min. at 2,500V AC		1 min. at 2,000V AC
Lightning impulse		±7kV 1.2 / 50 μs		±3kV 1.2 / 50 μs
Operating temperature		-5 to 40°C		
Insulation resistance		Insulation-resistance meter (1,000V DC) 1,000 MΩ		Insulation-resistance meter (500V DC) 1,000 MΩ
Overload capacity		1 sec. at 200 A AC		

* Operating current-carrying capacity as general terminal use: 30 A

HOW TO ORDER

[B-type test terminal]

B-PTT B MR

Basic type

Code	Structure / use
PTT	Single-contactor Structure
CTT	Dual-contactor Structure
C	Cover (Clear)
SV	Jumper
SB	
LB	

Code	Munsell color
4/1.5	7.5BG4/1.5
3/3.5	7.5BG3/3.5
R	7.5R4.5/14
Y	2.5Y8/12
B	N1.5

Code	Spec
(blank)	Standard
MR	Moisture resistance

[K-type test terminal]

K TT-A W 3-B M MR

Basic type

Test terminal

Code	Spec
A	For current
V	For voltage

Code	Contactor structure
S	Single contactor (Only for voltage type)
W	Dual contactor

Code	Front cover
(blank)	Removal type
M	Slide type

Code	Spec
(blank)	Standard
MR	Moisture resistance

Code	Munsell color
4/1.5	7.5BG4/1.5
B	N1.5

Code	Pole	Code	Pole
1	1 pole (*)	4	4 poles
2	2 poles	6	6 poles
3	3 poles	8	8 poles (*)

(*): Only for current type

[K-type test plug]

K TP-A 3 MR

Basic type

Code	Structure at the contactor's top
TP	Short contactor
TQ	Long contactor

Code	Spec
(blank)	Standard
MR	Moisture resistance
A	For current
V	For voltage

Code	Pole	Code	Pole
1	1 pole (*)	4	4 poles
2	2 poles	6	6 poles
3	3 poles	8	8 poles (*)

(*): Only for current type

[A-type test terminal or plug]

A TT-A 3

Basic type

Code	Spec
TT	Test terminal
TP	Test plug
TQ	Test plug (screw-type)

Code	Spec
A	For current (Circuit opening prevention)
V	For voltage (Power source contact prevention)
VL	For voltage (Circuit opening prevention)

Code	Pole	Code	Pole
2	2 poles	6	6 poles
3	3 poles	8	8 poles
4	4 poles		

● INSERTION TYPE



TEST TERMINALS

K-TYPE

STANDARD PRODUCTS (TERMINAL)

KTT-AW Pole No. Color (For current)

– Circuit opening prevention type –

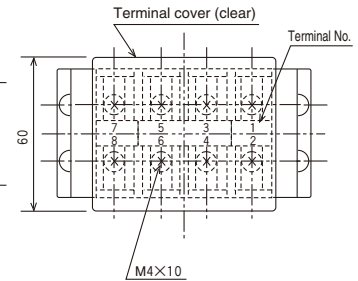
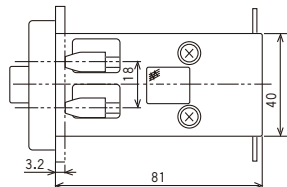
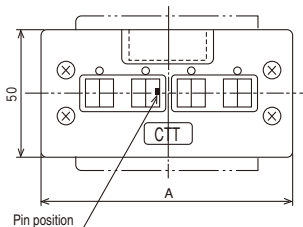

Pole	1	2	3	4	6	8
A	44	62	80	98	134	170

● Applicable plugs
 KTQ-A
 KTP-A

KTT-VW Pole No. Color (For voltage)

– Circuit opening prevention type –

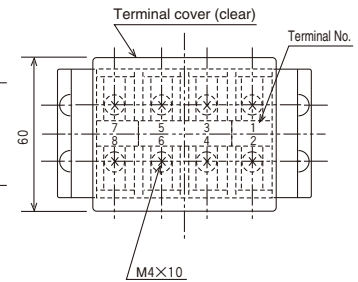
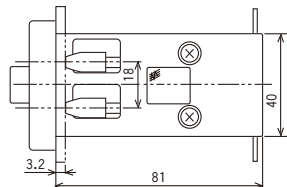
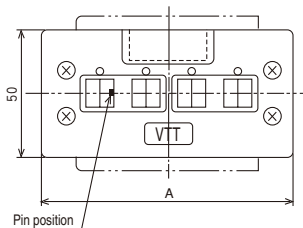

Pole	2	3	4	6
A	62	80	98	134

● Applicable plugs
 KTQ-V

KTT-VS Pole No. Color (For voltage)

– Power-source contact prevention type –

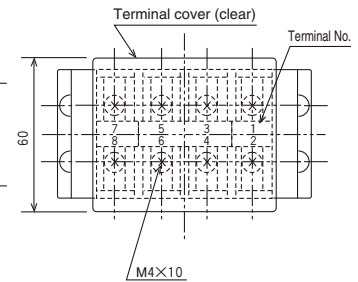
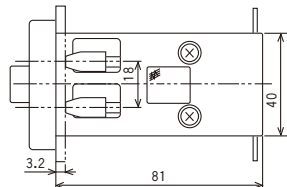
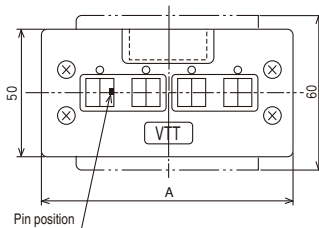

Pole	2	3	4	6
A	62	80	98	134

● Applicable plugs
 KTP-V

■ Combinations of test terminals and plugs, and applications

Test terminal	Test plug	Application
KTT-AW <input type="checkbox"/>	KTQ-A <input type="checkbox"/>	Combination of circuit disconnection prevention types (Recommendation)
	KTP-A <input type="checkbox"/>	Combination of circuit disconnection prevention types (Recommendation)
KTT-VW <input type="checkbox"/>	KTQ-V <input type="checkbox"/>	Combination of circuit disconnection prevention types (Recommendation)
KTT-VS <input type="checkbox"/>	KTP-V <input type="checkbox"/>	Combination of power-source contact prevention types (Recommendation)

⚠ Precautions on use

- To insert a test plug, be sure to lock the relay.
- If another power source is used when a voltage circuit is tested, select the combination of KTT-VS and KTP-V to prevent any contact with the test power source.
- In order to prevent any contact with the test power source, be sure to turn OFF the power switch when inserting a plug.
- For the purpose of preventing a momentary circuit disconnection. Combination of KTT-AW and KTQ-A are recommended for high contact reliability.

SLIDE COVER MODELS (TERMINAL)

KTT-AW Pole No. — Color (For current)

– Circuit open prevention type –

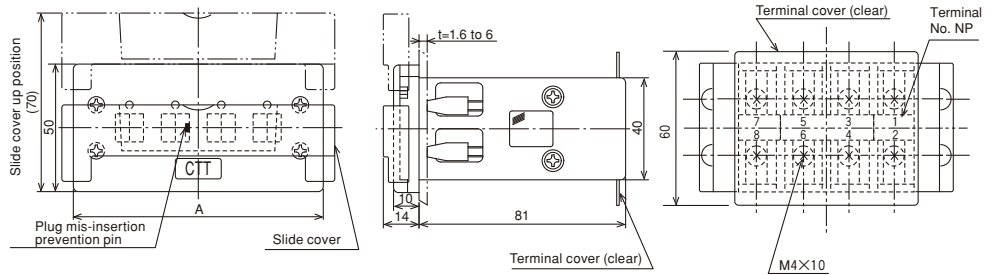
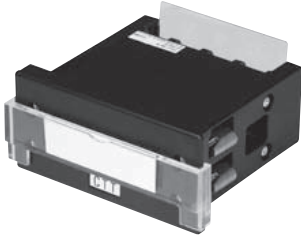

Pole	1	2	3	4	6	8
A	44	62	80	98	134	170

● Recommended plug type
 KTQ-A
 KTP-A

KTT-VW Pole No. — Color M (For voltage)

– Circuit open prevention type –

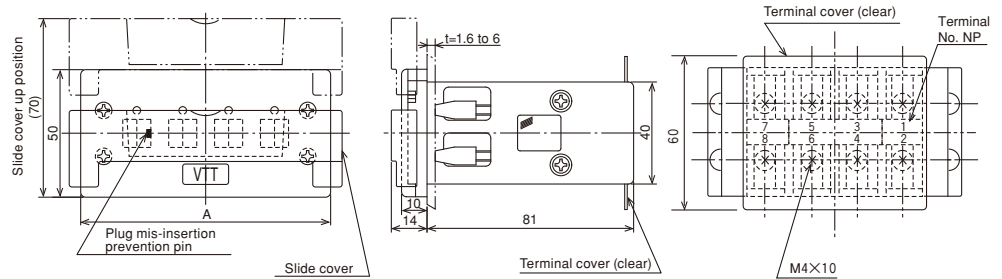
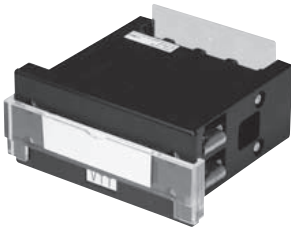

Pole	2	3	4	6
A	62	80	98	134

● Recommended plug type
 KTQ-V

KTT-VS Pole No. — Color M (For voltage)

– Power source contact prevention type –

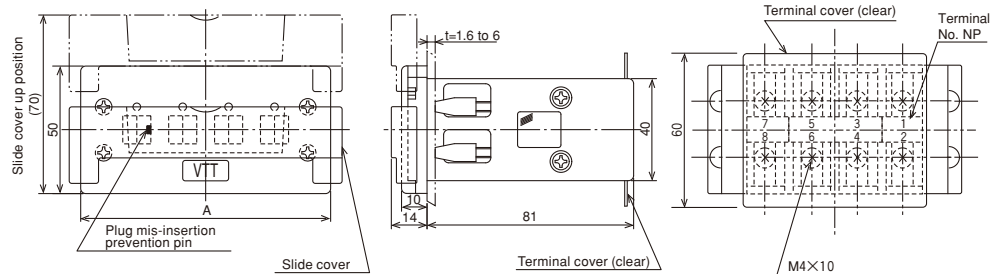
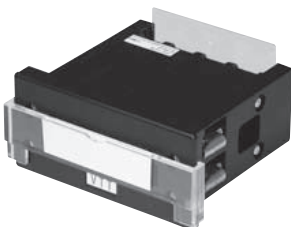

Pole	2	3	4	6
A	62	80	98	134

● Recommended plug type
 KTP-V



K-TYPE

STANDARD PRODUCTS (PLUG)

KTP-A Pole No. (For current)

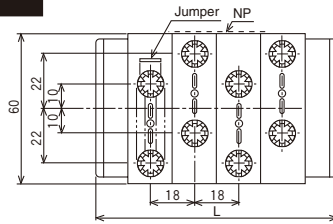
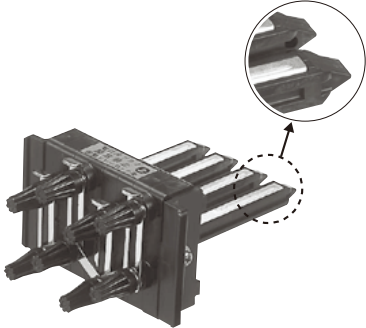

● Applicable terminal
KTT-AW□

Pole	1	2	3	4	6	8
L	44	62	80	98	134	170

Short conductive portion on plug top

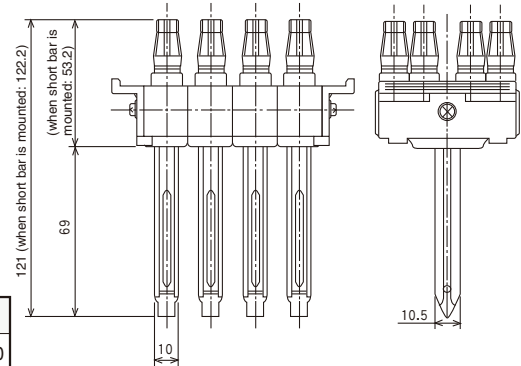

KTP-V Pole No. (For voltage)

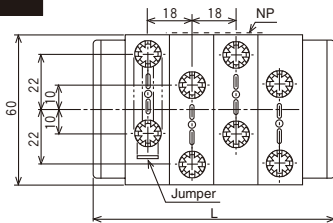
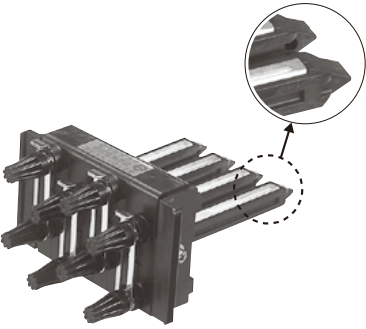

● Applicable terminal
KTT-VS□
KTT-VW□ (Recommended)

Pole	2	3	4	6
L	62	80	98	134

Short conductive portion on plug top

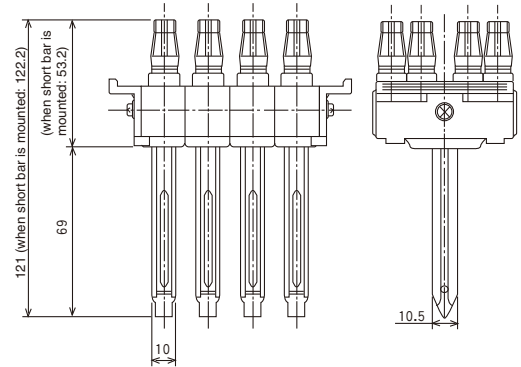

KTQ-A Pole No. (For current)

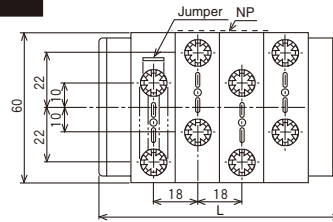
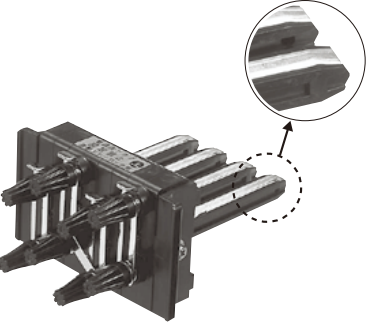

● Applicable terminal
KTT-AW□

Pole	1	2	3	4	6	8
L	44	62	80	98	134	170

Long conductive portion on plug top

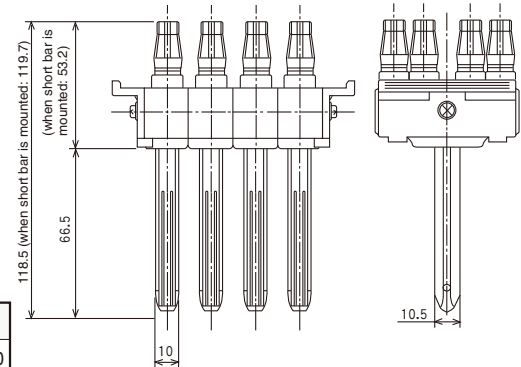

KTQ-V Pole No. (For voltage)

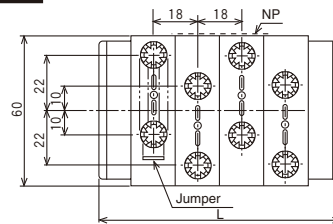
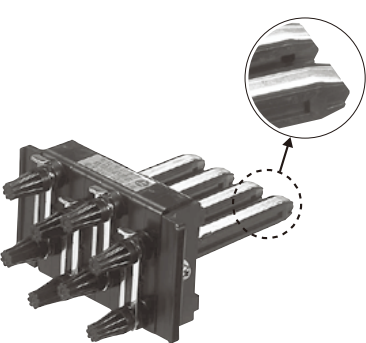

● Applicable terminal
KTT-VS□
KTT-VW□ (Recommended)

Pole	2	3	4	6
L	62	80	98	134

Long conductive portion on plug top

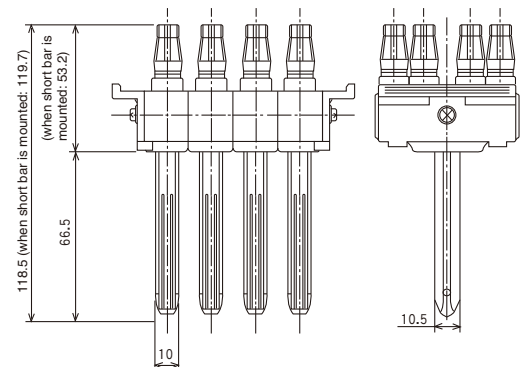

JUMPERS SUPPLIED WITH TEST PLUGS



KT jumper A (Vertical jumper) KT jumper B (Horizontal jumper)

The quantities of jumpers supplied are shown as below:

Model	Pole	KTP-A / KTQ-A						KTP-V / KTQ-V			
		1P	2P	3P	4P	6P	8P	2P	3P	4P	6P
KT jumper A		—	2	3	4	6	8	2	3	4	6
KT jumper B		—	1	2	3	5	7	—	—	—	—

ACCESSORIES

Box set of plugs



Box set for KTPB plugs



Model	Description
KTPB-A2-V2	KTP-A2 1 piece
	KTP-V2 1 piece
	Red, white wire 4 pieces each
KTPB-A3-V3	KTP-A3 1 piece
	KTP-V3 1 piece
	Red, white, blue wire 4 pieces each
KTPB-A4-V4	KTP-A4 1 piece
	KTP-V4 1 piece
	Red, black, white, blue wire 4 pieces each
KTPB-A6	KTP-A6 1 piece
	Red, white, blue wire 4 pieces each
KTPB-V6	KTP-V6 1 piece
	Red, white, blue wire 4 pieces each
KTPB-A8	KTP-A8 1 piece
	Red, black, white, blue wire 4 pieces each

*Jumpers are included.
*Set of KTP and KTQ is also available.

Box set for KTQB plugs

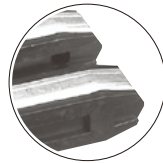

Model	Description
KTQB-A2-V2	KTQ-A2 1 piece
	KTQ-V2 1 piece
	Red, white wire 4 pieces each
KTQB-A3-V3	KTQ-A3 1 piece
	KTQ-V3 1 piece
	Red, white, blue wire 4 pieces each
KTQB-A4-V4	KTQ-A4 1 piece
	KTQ-V4 1 piece
	Red, black, white, blue wire 4 pieces each
KTQB-A6	KTQ-A6 1 piece
	Red, white, blue wire 4 pieces each
KTQB-V6	KTQ-V6 1 piece
	Red, white, blue wire 4 pieces each
KTQB-A8	KTQ-A8 1 piece
	Red, black, white, blue wire 4 pieces each

*Jumpers are included.
*Set of KTP and KTQ is also available.

Jumper

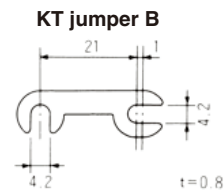
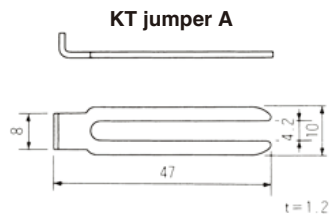

● Jumpers are supplied as standard equipment.

Nameplate for usage display [common to KTT and ATT]

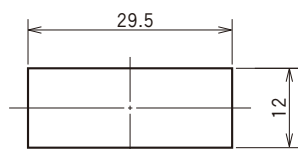

● The material is single-side coated paper (white). (Ordering unit: 100 pieces)

Indicated character	CT secondary	PT secondary	GPT secondary	GPT third	Blank
Code	PT2RY	VT2RY	GPT2RY	GPT3RY	CT2RY



K-TYPE

STRUCTURES AND EACH COMBINATION CHARACTERISTIC

**Diagram of
contactor for current
(KTT-AW□)**

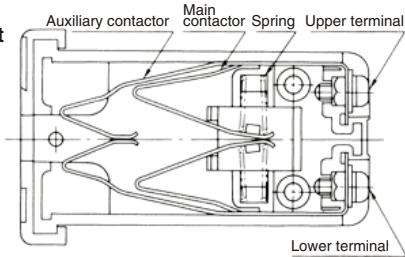

**Diagram of
contactor for voltage
(KTT-VS□)**

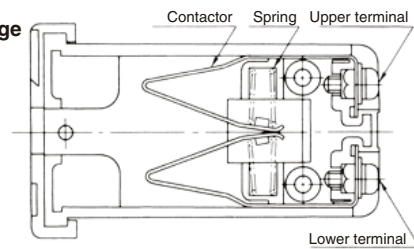

When a plug is inserted and the auxiliary contactor is opened, the main contactor will not be opened. The auxiliary contactor closes before the plug releases the main contactor. Either the auxiliary contactor or the main contactor always make circuit with a plug, preventing the CT circuit opening.

When the plug is inserted, the contactor is opened. This state will be maintained until the contactor makes contact with the contact point of the plug. This eliminates the possibility of making contact with the power source.

■Combination of KTT-AW and KTQ (Recommended)

The KTT-AW terminal has a dual-contactor structure consisting of main and auxiliary contactors. In addition, the KTQ plug has a long conductive part for contact up to its leading end. Therefore, when the plug is inserted, the contact is completed at two contacts (A) and (B) before the contact (C) of the terminal is opened. Thus, this combination provides excellent function for preventing the circuit from being opened.

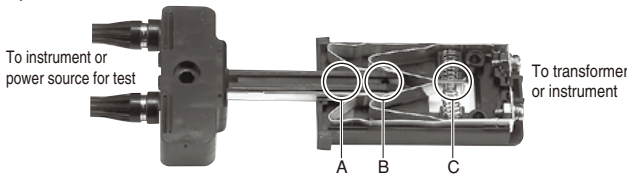

■Combination of KTT-VS and KTP (Recommended)

The KTT-VS has a single-contactor structure consisting of a main contactor only. The KTP has a long conductive part for contact up to 10 mm before its leading end (the leading 10 mm part is an insulator). When the plug is inserted, the contact (C) of the terminal is opened before the contact (B) is closed. Therefore, even if another power source is inserted from the plug when the plug is inserted or removed, there will be no possibility of making contact with the power source. However, when the circuit voltage is measured with a test instrument, the relay will malfunction due to the momentary disconnection of the circuit. For this reason, the relay must be locked.

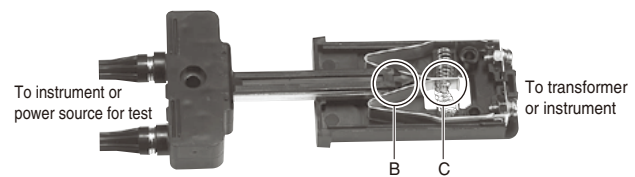

■Combination of KTT-AW and KTP

The KTT-AW has a dual-contactor structure consisting of main and auxiliary contactors. The KTP plug has a shorter conductive part for contact than the KTQ. However, when it is inserted, the contact (A) of the terminal is closed before the contact (C) is opened (the contact (B) starts being closed after the contact (C) has been opened).

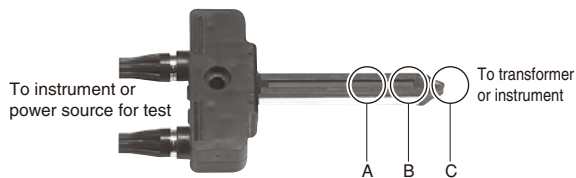

■Combination of KTT-VS and KTQ (special combination)

The KTT-VS has a single-contactor structure consisting of a main contactor only. However, the KTQ has a long conductive part for contact up to its leading end. Therefore when the plug is inserted, the contact (B) of the terminal is closed before the contact (C) is opened.

This ensures that the circuit never be opened when the plug is inserted or removed. Therefore, when the circuit voltage is measured using a test instrument, the relay will not malfunction due to the momentary disconnection of the circuit. However, if you try to insert another power source from the plug, a temporary connection with the power source will occur.

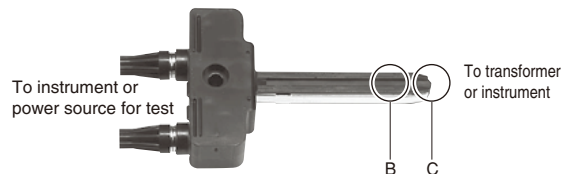

PANEL CUTOUT DIMENSIONS

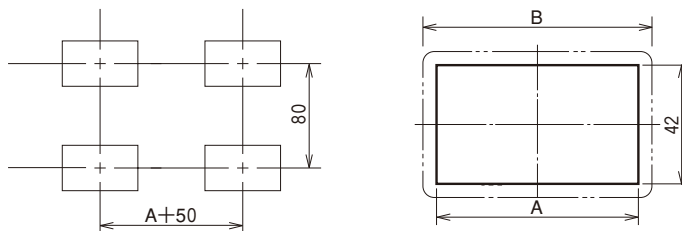

(Min. mounting pitch)

Size	1P	2P	3P	4P	6P	8P
A	36	54	72	90	126	162
B	44	62	80	98	134	170

DIRECTIONS FOR MOUNTING

Mounting procedure

- Mount the test terminal from the front of the panel (remove the terminal cover).

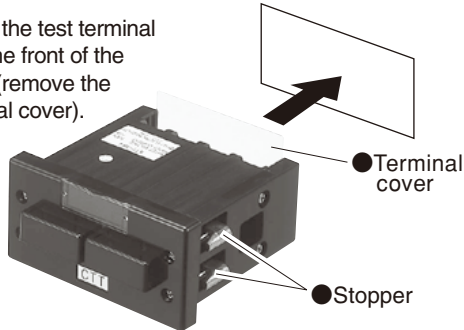

(Take care so that the stoppers do not hit against any panel edge.)

- Tighten the mounting screws by turning them clockwise with a Philips screwdriver.

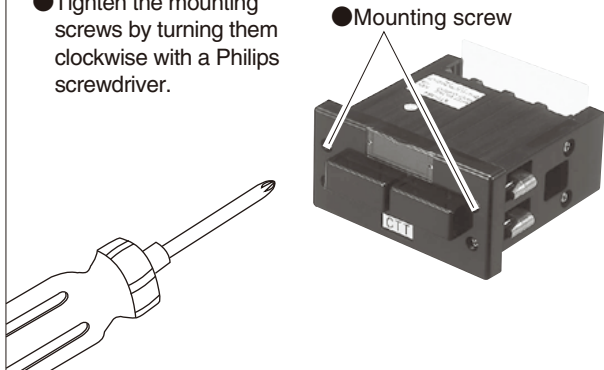

OPERATING INSTRUCTIONS

Measuring current and voltage

Voltage

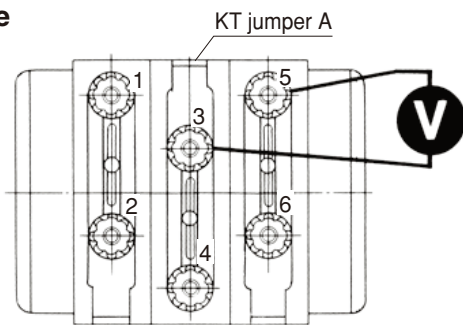

1. Short-circuit each phase (each set of the upper and lower terminals represents the same phase) with the KT jumper A.
 2. Connect a voltmeter circuit between the phases to be measured.
 3. After the connection, insert the plug into the terminal.
- Note: Be sure not to insert the plug with wrong phases short-circuited because it is dangerous to short-circuit PT secondary circuit. The KT jumper B (for short-circuiting different phases) does not come with the KTP-V and KTQ-V.

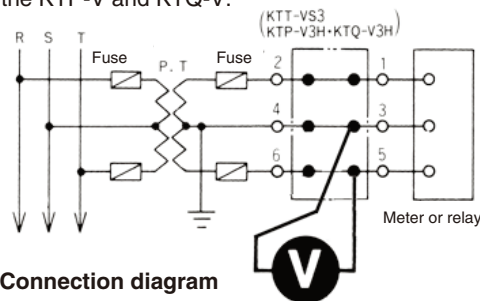

Connection diagram

* When inserting the plug, take care not to touch with the short bar or other.

Current

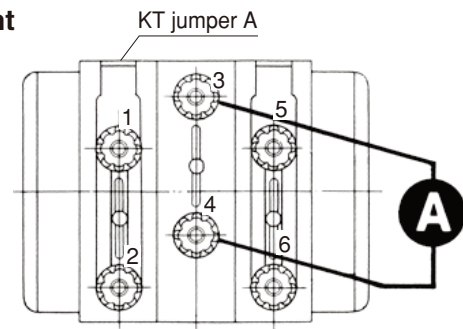

1. Connect an ammeter circuit between the poles to be measured.
 2. Short-circuit the other phases with the KT Jumper A.
 3. After the connection, insert the plug.
- Note: Opening the CT circuit creates a dangerous situation. Be sure to avoid inserting the plug without ensuring the proper connection. Be sure to avoid inserting the plug with wrong connection because it is dangerous to open CT circuit.

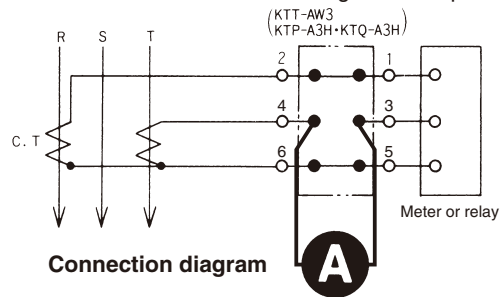

Connection diagram



K-TYPE

Calibrating a meter and testing a relay with the test power source

For voltage meter

1. Connect the power source for test to the upper terminal screw on the plug for voltage.
2. Connect nothing to the lower terminals to keep it open.
3. After the connection, insert the plug into the test terminal and then carry out calibration and others.

For current meter

1. Connect the power source for test to the upper terminal screw on the plug for current.
2. Connect the KT jumper B to the lower terminal to prevent the CT circuit from being opened.
3. After the connection, insert the plug into the test terminal and then carry out calibration and others.

KT jumper B

* Note: Before connecting the power source for test, carefully check that it is connected to the correct terminals (not the vertically reverse ones). To insert the plug, be sure to turn OFF the power switch.

Checking for electrical discontinuity or breakdown in internal wiring of board

Secondary side of current transformer

1. Connect an insulation-resistance meter between the test plugs TP(1) and TP(2).
2. Insert the connected plug into the test terminal TT(1) and TT(2), and then measure the block A.
3. Similarly, measure the block B to the final block.
4. Insulation resistance for each block can be measured.

* Note: Before inserting the plugs, short-circuit all the terminals on the entire primary side of the current transformer with the KT jumper B.

WIRING INSTRUCTION

Terminal: KTT-AW

Plug: KTP-A / KTQ-A

CT 1 unit Secondary output measurement		CT 1 unit Current calibration	
<p>Circuit</p>	<p>Connecting position</p>	<p>Circuit</p>	<p>Connecting position</p>
CT 2 units Secondary output measurement		CT 2 units Current calibration	
<p>Circuit</p>	<p>Connecting position</p>	<p>Circuit</p>	<p>Connecting position</p>
CT 3 units Secondary output measurement		CT 3 units Current calibration	
<p>Circuit</p>	<p>Connecting position</p>	<p>Circuit</p>	<p>Connecting position</p>